

### ABSTRACT

Hydroponic is the different planting method followed in agriculture. This method is based on water and does not depend on soil. Here the nutrient is added with water and the plants are grown in water. This method need continuous monitoring for growing and automatic system used here will fulfill the demand. This automatic system control the water pH level, water temperature, surrounding temperature and humidity. In addition it can be monitored remotely using IOT. The sensors used are pH sensor, Temperature and humidity sensor, water proof temperature sensor.

**KEYWORDS:** automatic control for hydroponics, remote monitoring.

### INTRODUCTION

Agriculture is a most important thing in human's day to day lives. Agriculture will fulfill the food demand of humans. Because of growth in population and industries the agricultural lands are occupied, thus the agriculture has been affected and so the food demand got increased. So we need different method to cultivate plant. The above problems can be overcome by using soilless culture. Thus, hydroponic is used which is a technique to grow plant without using soil. This system has many advantages than soil based gardening. It uses less water, small space, produce more product and healthy food. The fruits, vegetables and flowers can be harvested by using this technique.

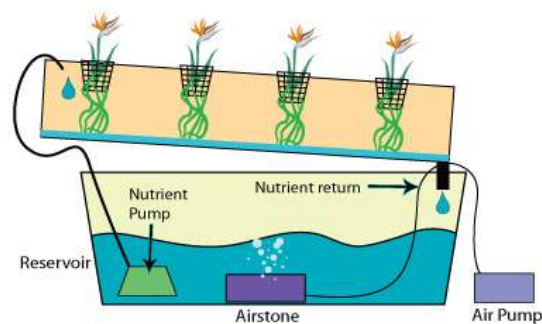

Figure 1: Basic Hydroponic Module

This method contains a cultivation tank and it is filled by water with appropriate nutrients needed by the plant. This solution has perfectly balanced nutrient solution which helps to harvest the healthiest crops. Nutrients are directly given to the roots of the Hydroponic plant continuously. The roots absorb a balanced nutrient solution dissolved in water that meets all the plants developmental requirements. The solution near to the roots is much influenced by the environmental factors like salinity, oxygenation, temperature, pH and conductivity of nutrient solution, light intensity, photoperiod and air humidity. The electrical conductivity and potential of hydrogen ions are the two important factors considered in hydroponic planting method. Due to the change of pH level in water the photosynthetic activity of the plant will get affected. The pH level in the water should be controlled to avoid the plant damage. Here an automatic control system is designed. This automatic system control the water pH level, water temperature, surrounding temperature and humidity. In addition it can be monitored remotely using IOT.

[Vuvaraju\* *et al.*, 6(5): May, 2017]  
 ICTM Value: 3.00

The sensor used is pH sensor, temperature and humidity sensor, water proof temperature sensor. In our system have four stages, they are

- [1] Planning
- [2] Auto control
- [3] monitoring
- [4] harvest recording

**RELATED WORK**

To develop our application we have to know about hydroponic planting techniques, the necessary nutrient used for the plant growth, about pH values of the solution. For growing healthy plants and to produce high yields the precise control of hydroponic nutrients is essential. The following table describes the necessary nutrients required for the plants.

*Table 1: Necessary nutrient for the plant*

| LARGE                               | INTERMEDIATE                    | SMALL  |
|-------------------------------------|---------------------------------|--|
| Nitrogen<br>Phosphours<br>Potassium | Calcium<br>Sulphor<br>Magnesium | Iron<br>Manganese<br>Zinc<br>Boron<br>Molybdenum |

pH value is a measure of acidity or alkalinity of water solution. The acidity or alkalinity of a water solution is determined by the relative number of hydrogen ions or hydroxyl ions present. Most plant prefers the pH range of 5.5 to 7.0. For example the pH of tomato should lie within 5.5 – 6.5 of the nutrient solution. In closed hydroponic system an automated sensing of macronutrients would allow more efficient management of nutrients for crop growth [2].

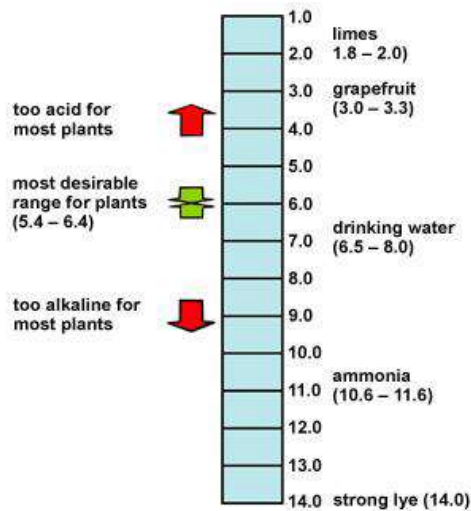

*Figure 2: pH level in water*

The range of pH value and its corresponding effect on the plant system are described in the table [2].

*Table 2: pH effect on the plant*

| pH Range   | Plant Response                            |
|------------|---|
| pH <3      | Roots membranes will get damaged          |
| 3 < pH < 5 | Roots will be infected by fungal diseases |

|            |  |
|------------|--|
| 5.2<pH<5.5 | Solubility of phosphoric acid, calcium and magnesium will drop |
| 5.5<pH<6.5 | Optimal range  |
| 6.5<pH<7.5 | Nutrient intake is reduced                                     |
| pH>7.5     | Iron, manganese, copper, zinc and boron are less available     |

### SYSTEM ARCHITECTURE

The automatic controlling of hydroponic gardening is designed here. This system consists of three sensors and they are:

- 1) pH sensor
- 2) Humidity sensor
- 3) Water temperature sensor

In this project we use DHT11 temperature and humidity sensor. This is a digital output relative humidity and temperature sensor, it uses a capacitive humidity sensor and a thermistor to measure the surrounding air and spits out a digital signal on the data pin. To find water temperature we use DS18B20 water proof temperature sensor. The DS18B20 digital thermometer provides 9-bit to 12-bit Celsius temperature measurements. pH sensors measure hydrogen ion activity and produce a voltage. The sensor operates based on the principle that an electric potential. It ranges from 0.001 to 14.0

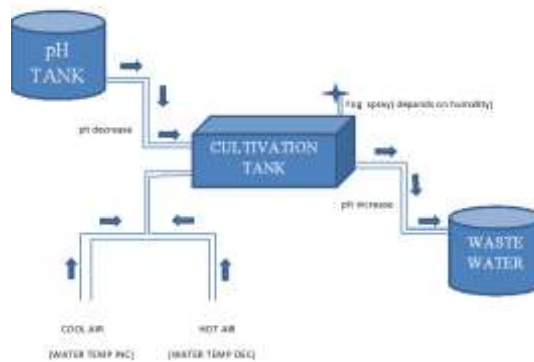

**Figure 3: Automatic Hydroponic module**

The pH and water temperature sensors are fixed within the solution and the humidity sensors are placed within the planting table. Fill motor fixed in between the pH tank and cultivation tank. Similarly drop motor connected in between cultivation tank and wastage tank. Fog spray motor is placed above the cultivation tank and air pump connected to the water solution via valve. The entire three sensors are controlled by the Arudino mega.

There are four stages in this system and each one is explained below:

#### Planning:

This stage prepares a blueprint of gardening. And it includes gardening location it may be indoor or outdoor, size of the garden, type of container used, which plant to be planted, requirements of that plant it means range of pH, water temperature and humidity needed. And prepare nutrient solution.

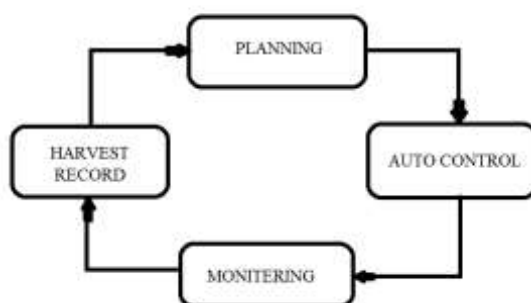

Figure 4: Functional overview

**Auto control:**

In this stage hydroponic gardening is controlled automatically with help of three sensors. The corresponding values are entered using the keypad for the concern plant and also provided the necessary water temperature, humidity and pH to that plant. The pH sensor measures the pH value and send to the controller. The controller compares the solution pH along with the reference pH thus the water temperature sensor sense the temperature value and send to the controller which compare the solution temperature along with the reference temperature. The humidity value is compared with the reference value and this operation is carried out continuously.

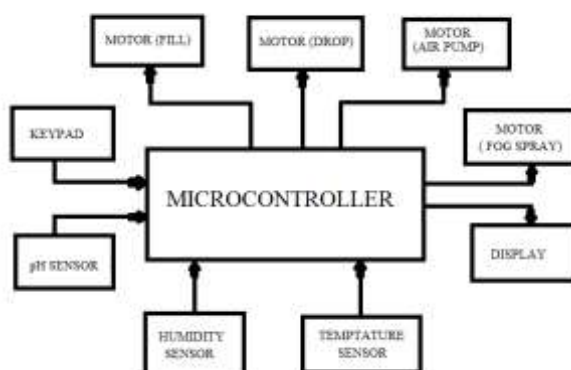

Figure 5: Block diagram of automatic system

Any changes in given parameter value is automatically corrected using a microcontroller. For example pH value is less than given value means, fill motor will be ON and fill the nutrient solution to the cultivation tank. Once it has reached given value drop motor is stopped. If surrounding temperature is more than given value fog spray will be on until it reach corresponding temperature. Similarly air pump is operated depending on water temperature condition. Air may be hot or cool and is desired by given parameter.

Table 2: Function Table

| PARAMETER  | INCREASE                        | DECREASE                        |
|------------|---------------------------------|---------------------------------|
|            | Drop motor on<br>Fill motor off | Drop motor off<br>Fill motor on |
| HUMIDITY   | Fog spray on                    | Fog spray off                   |
| WATER TEMP | Pumping cool air                | Pumping hot air                 |

[Vuvaraju\* *et al.*, 6(5): May, 2017]  
 ICTM Value: 3.00

**Monitoring:**

In this section user can monitor the plant remotely. Here user see the sensor values and environmental parameter readings system function etc., If user fix the camera in garden he additionally get the video streaming . The above details are sent to the server and this can be achieved by the use of IOT.

**Harvesting record:**

This is the final stage of our system. This section is very useful for future reference. Here user notification, sensor values and environmental factor, system function and all helpful information are saved on the server.

**RESULTS AND DISCUSSION**

Here three parameters are being considered. They are pH parametric range, humidity parametric range and water temperature parametric range. Depends on the parameter the system will be operated. If pH range is varied from given value the fill and drop motor will be ON with respect to increasing or decrease the pH value.

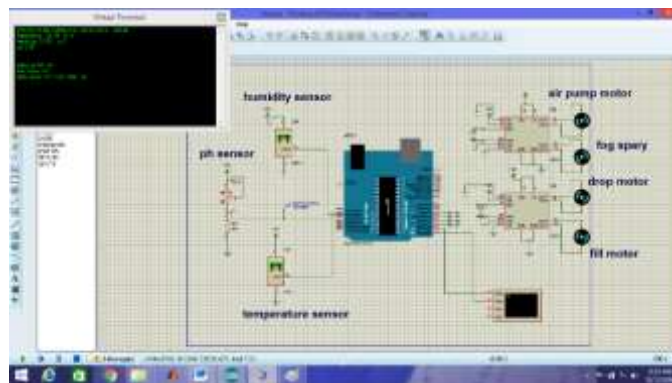

Figure 6: Simulation Output

If given humidity range is varied, fog spray motor is ON or OFF with respect to increase and decrease of the humidity value respectively. Similarly water temperature range is varied following action will be happen. If water temperature is increased then cool air is pumped into the water. If temperature decreases hot air is pumped into the water.

SENSOR

Hydroponics Sensor Monitoring

| PH level | Temperature | Humidity | liquid Temperature |
|----------|-------------|----------|--------------------|
| 4.2      | 32          | 39       | 25                 |

Powered by OOBweath

Figure 7: Monitoring Output

Above figure shows the monitoring parameter. It means displays the sensors output to the mobile via mobile application using IOT.

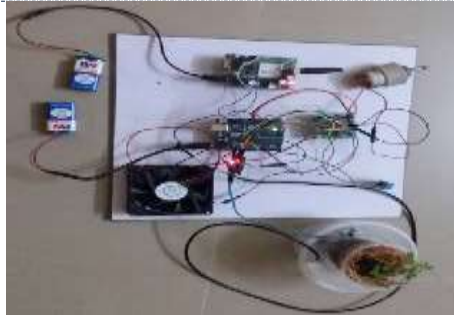

**Figure 8: Hardware Module**

## CONCLUSION

Design of automatic system for hydroponic gardening was successfully done with use of sensors and Arduino mega microcontroller. It successfully manages the pH level in nutrient solution. And also maintain the correct water temperature and surrounding humidity. In addition it sends the gardening information to the user and save the information for future reference. This application is helpful for the user to increase the productivity and to produce healthiest product in hydroponic gardening.

## REFERENCES

- [1] Diego S. Domingues, Hideaki W. Takahashi, Carlos A.P. Camara, Suzana L. Nixdorf published a journal on the concept of "Automated system developed to control pH and concentration of nutrient" in the year of 2012.
- [2] F. Xavier Rius-Ruiz, Francisco J. Andrade, Jordi Riu, F. Xavier Rius published a journal on the concept of "Computer- operated analytical platform for the determination of nutrients in hydroponic systems" in the year of 2013.
- [3] M.F. Saaid, N.A.M. Yahya, M.Z.H. Noor, M.S.A. Megat Ali published a journal on the concept of "A Development of an Automatic Microcontroller System for Deep Water Culture (DWC)" in the year of 2015.
- [4] Johnson A. Asumadu, Boris Smith, Niiman S. Dogan, published a journal on the concept of "Microprocessor-based instrument for hydroponic growth chambers used in ecologi cal life suippport systems" in the year of 1996.
- [5] Jyh-Shyan Chiu, Shinn-Fwu Wang, Wen-June Wang,published a journal on the concept of "Application of Total Internal Reflection and Heterodyne Interferometry in Electrical Conductivity Measurements" in the year 2016.
- [6] Hak-Jin Kim, Won-Kyung Kim, Mi-Young Roh , Chang-Ik Kang , Jong-Min Park ,Kenneth A. Sudduth published a journal on the concept of "Automated sensing of hydroponic macronutrients using a computer-controlled system with an array of ion-selective electrodes "in the year of 2013.
- [7] P. S. Huang and J. Ni, "Angle measurement based on the internal-reflection effect and the use of right-angle prisms,"Appl. Opt. **34**, 4976–4981 \_1995\_.
- [8] P. S. Huang and J. Ni, "Angle measurement based on the internal-reflection effect using elongated critical-angle prisms," Appl. Opt. **35**, 2239–2241 \_1996\_.